ECE 333 – Green Electric Energy

6. Limits on Conversion of Wind Into Electricity

George Gross

**Department of Electrical and Computer
Engineering**

University of Illinois at Urbana-Champaign

CONVERSION OF WIND INTO ELECTRICITY

- We analytically characterize the power in wind as a cubic function of the wind speed v
- The wind energy is in the form of kinetic energy, which is extracted from the wind and used to rotate the generator shaft mounted in the nacelle
- We examine the constraint – the so-called *Betz limit* – that restricts the ability of a wind turbine to convert kinetic energy into mechanical energy to spin the turbine generator shaft

THE BETZ LIMIT

- ❑ The limit was derived in 1919 by Albert Betz, a German physicist
- ❑ We consider the wind as it passes through a wind turbine and we examine the wind stream
- ❑ We explain the conceptual basis on the limit of the conversion of wind into electricity using the diagram below

THE BETZ LIMIT

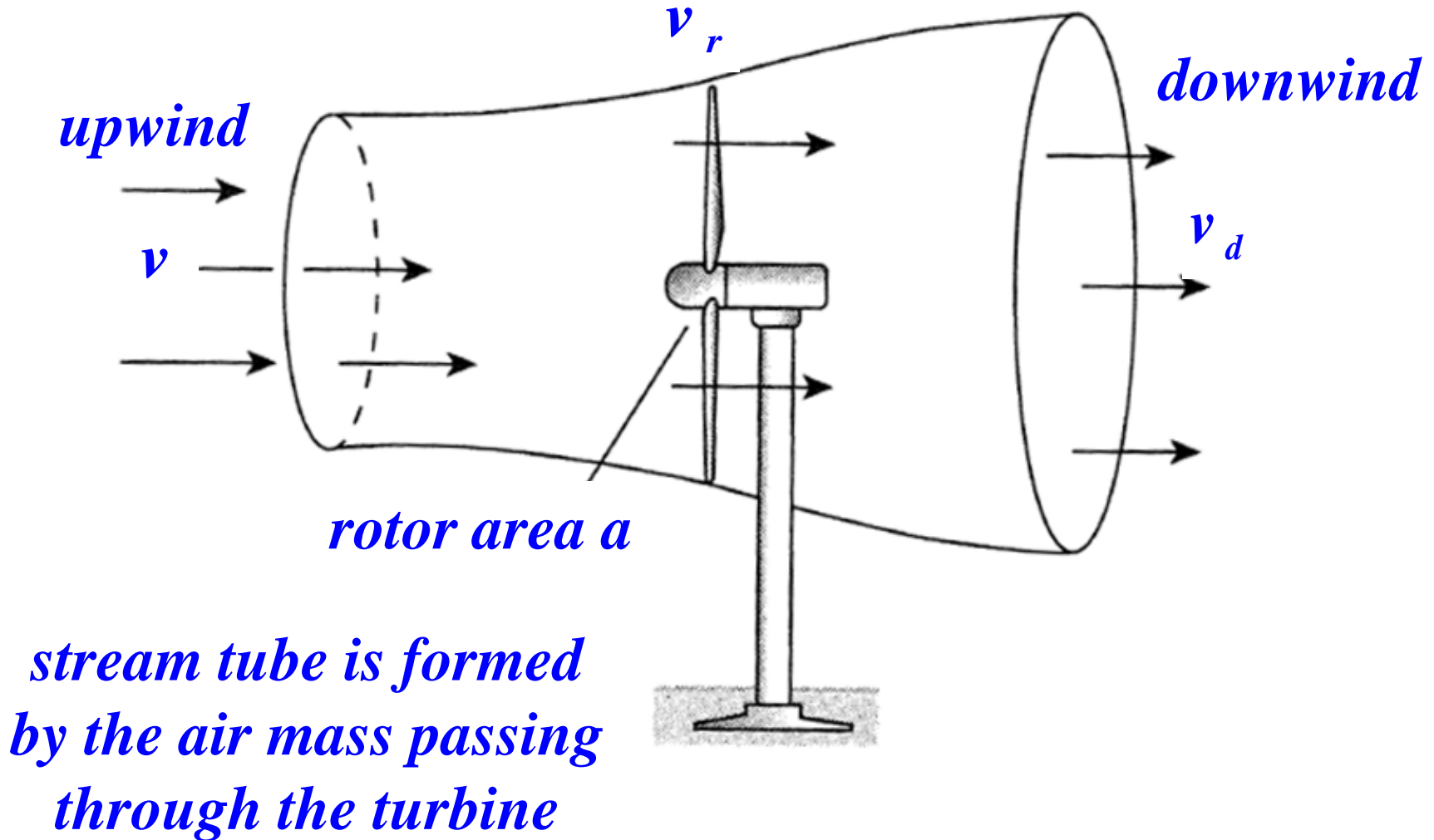

THE BETZ LIMIT

- ❑ Clearly, the turbine cannot extract all the kinetic energy in the wind because that implies that the air would have to stop completely after passing the turbine – an impossible situation since it would prevent all the continuing wind to pass through the rotor
- ❑ Furthermore, the downwind velocity v_d *cannot equal* v since that would imply that no energy is extracted by the turbine

THE BETZ LIMIT

- Betz formulated the relationship to determine the maximum mechanical power obtainable from wind
- We focus on what happens with the wind as it passes through the plane of the rotor blades at velocity v_r , with

$$v_d < v_r < v,$$

where, we explicitly take into account that as the wind mass of air goes through the stream tube, the downwind speed is lower than the upwind speed

THE BETZ LIMIT

- The conservation of energy implies that

$$\begin{array}{rcc} \textit{kinetic energy} & & \textit{kinetic energy} \\ \textit{upwind} & = & \textit{downwind} \end{array} + \begin{array}{l} \textit{energy extracted} \\ \textit{by blade rotor} \end{array}$$

- Therefore, as the mass flow rate $\frac{dm}{dt}$ throughout the stream tube remains unchanged, the power extracted by the rotor blades is

$$\begin{aligned} P_r &= \frac{d}{dt} \left(\begin{array}{cc} \textit{kinetic} & \textit{kinetic} \\ \textit{energy} & \textit{energy} \\ \textit{upwind} & \textit{downwind} \end{array} - \right) \\ &= \frac{1}{2} \frac{dm}{dt} \left(v^2 - v_d^2 \right) \end{aligned}$$

THE BETZ LIMIT

□ Now, we can determine $\frac{dm}{dt}$ anywhere in the stream tube and at the rotor blade plane since

$$\frac{dm}{dt} = \rho a v_r$$

and we assume that

$$v_r = \frac{v + v_d}{2}$$

so that

$$P_r = \frac{1}{2} \rho a \left(\frac{v + v_d}{2} \right) \left(v^2 - v_d^2 \right)$$

THE BETZ LIMIT

□ We introduce the ratio λ defined by

$$v_d = \lambda v$$

so that the expression for p_r becomes

$$\begin{aligned} p_r &= \frac{1}{2} \rho a v \left(\frac{1 + \lambda}{2} \right) v^2 (1 - \lambda^2) \\ &= \underbrace{\frac{1}{2} \rho a v^3}_{\text{power in the wind}} \underbrace{\frac{1}{2} (1 + \lambda)(1 - \lambda^2)}_{\text{fraction extracted}} \end{aligned}$$

THE BETZ LIMIT

- We can think of the fraction of power extracted by the rotor as the efficiency η_r of the rotor

$$\eta_r = \frac{1}{2}(1 + \lambda)(1 - \lambda^2)$$

so that

$$p_r = \frac{1}{2} \rho a v^3 \eta_r$$

THE BETZ LIMIT

□ To determine the maximum rotor efficiency we evaluate the derivative of p_r w.r.t. λ

$$\begin{aligned}\frac{dp_r}{d\lambda} &= \frac{1}{2}\rho av^3 \frac{1}{2}[(1+\lambda)(-2\lambda) + (1)(1-\lambda^2)] \\ &= \frac{1}{4}\rho av^3 [-2\lambda^2 - 2\lambda + 1 - \lambda^2] \\ &= \frac{1}{4}\rho av^3 [1 - 2\lambda - 3\lambda^2] \\ &= \frac{1}{4}\rho av^3 [(1+\lambda)(1-3\lambda)]\end{aligned}$$

THE BETZ LIMIT

□ We set $\frac{dp_r}{d\lambda}$ to be 0, and we solve for λ

□ The only physically meaningful solution is

$$\lambda = \frac{1}{3},$$

i.e., the efficiency is maximized when the ratio of

v_d to v is 1/3 so that

THE BETZ LIMIT

$$\eta_r = \frac{1}{2} \left(1 + \frac{1}{3} \right) \left(1 - \frac{1}{3^2} \right) = \frac{16}{27} = 59.3 \%$$

□ This optimal theoretical efficiency – better known

as the *Betz efficiency* – cannot be higher than

59.3%; this value is the essence of the *Betz limit*

THE BETZ LIMIT

- The *Betz* limit implies that even under ideal conditions less than 60 % of the power in wind can be extracted and in actual systems, the best that is attainable is, typically, below 50 %; in other words, at most half of the power in wind can be converted into mechanical power to rotate the generator shaft

TIP SPEED RATIO

- The tip speed of the rotor is a function of the rate of rotation of the rotor specified by its *r.p.m.*: in each revolution of the rotor, the tip traverses a distance πd and so the tip speed is $(\pi d)(r.p.m.)$
- A convenient way to express rotor efficiency is in terms of the tip speed ratio τ , where

$$\tau = \frac{\text{rotor tip speed}}{v} = (r.p.m.) \cdot \frac{\text{min}}{60 \text{ sec}} \cdot \frac{\pi d}{v}$$

TIP SPEED RATIO

- ❑ **Studies indicate that modern turbines attain maximum efficiency for $4 \leq \tau \leq 6$: the tip of the blade moves 4 – 6 times faster than the wind speed**
- ❑ **It follows that for maximum efficiency it is desirable that turbine blades change their speed as speed changes – as is the case in variable speed generators**

INTERPRETATION OF η_r

- Betz's law states that the maximum power that we can extract from wind is

$$P_r = \left(\frac{1}{2} \rho a v^3 \right) 0.593$$

- Engineers define the efficiency as the ratio of the output to the input quantity

$$\eta_r = \frac{P_{out}}{P_{in}}$$

and so the question is what is P_{in}

INTERPRETATION OF η_r

- A convenient way to think about P_{in} is that P_{in} is the power in the wind prior to the installation of a turbine: without the turbine installed, $v_r = v$ thus

$$P_{in} = \frac{1}{2} \rho a v^3$$

- Betz efficiency provides the limit on the conversion of this power into mechanical power to rotate the generator shaft

WIND TURBINE GENERATORS

- ❑ The wind turbine generators or wind energy conversion systems may be classified into two principal categories
 - variable speed rotors
 - fixed speed rotors
- ❑ The variable-speed turbines have the ability to take advantage of the fact that wind speed is

WIND TURBINE GENERATORS

variable and adjust the rotor speed so as to optimally match wind speed

- ❑ The fixed-speed rotor generators are simpler but cannot operate at optimal efficiency; due to the stresses from the rapidly changing wind speeds, such turbines, typically, require sturdier design

WECS TYPE A

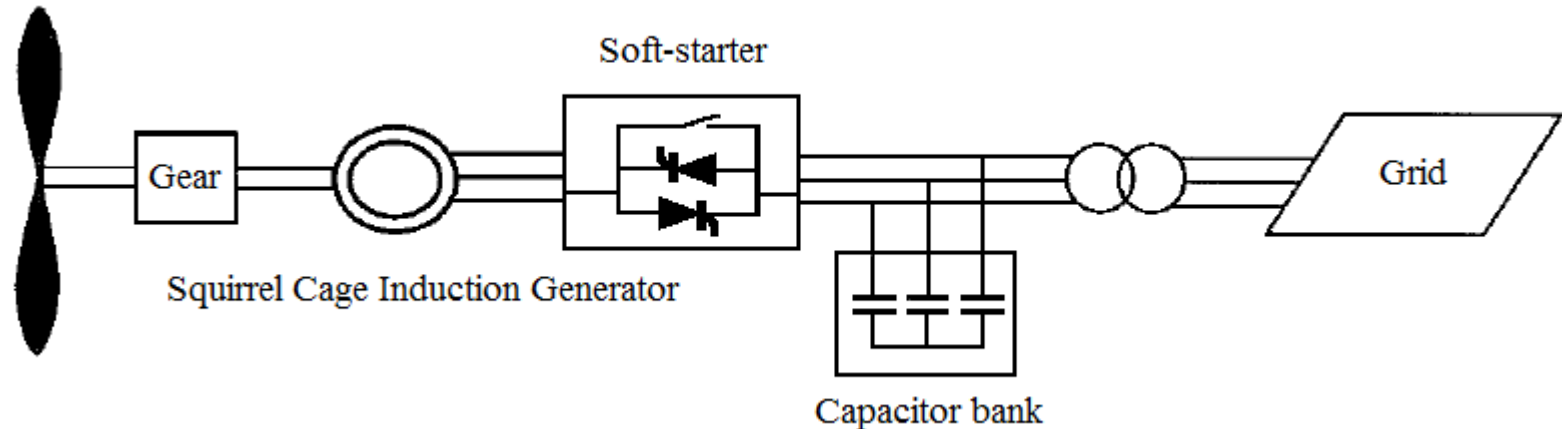

- ❑ The turbine design uses an induction generator connected to a fixed-speed wind turbine
- ❑ This design needs two additional components for grid connection:

WECS TYPE A

- a soft-starter to decrease current transients during startup phase
- a capacitor bank to compensate for reactive power

□ As a result of the capacitor bank, the generator can work close to a zero value generation or consumption of reactive power

□ Unfortunately, such a capacitive compensation scheme does not allow flexible reactive power control

WECS TYPE B

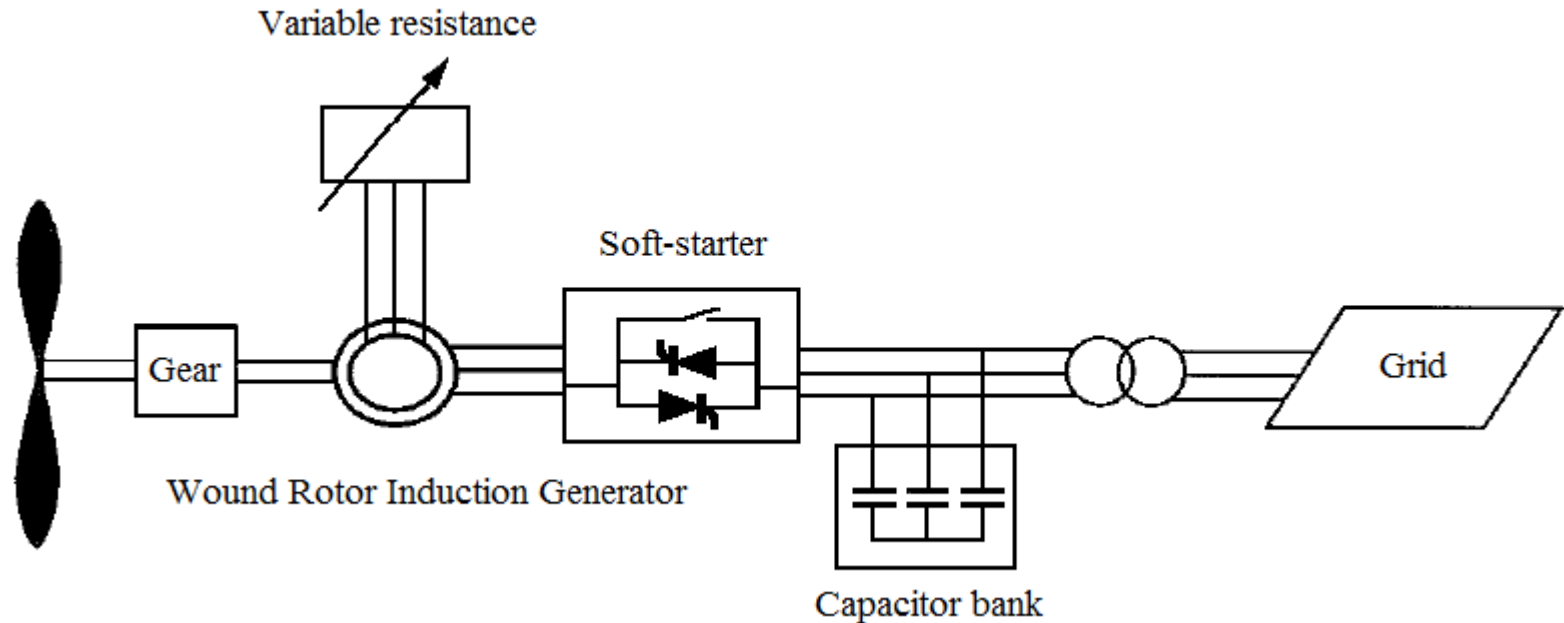

- The *Vestas-developed type B WECS* generator is designed to work with a limited variable speed

WECS TYPE B

wind turbine

- With the variable resistor in the rotor, it is possible to control the real power output
- The capacitor bank and soft-starter role is analogous to that in the the *type A* design

WECS TYPE C

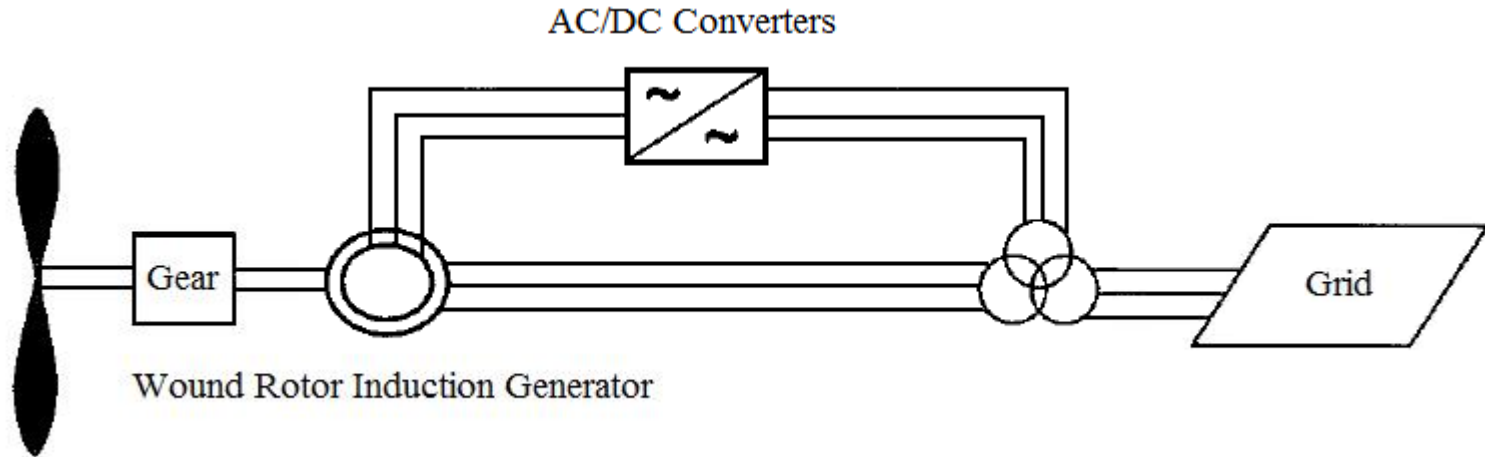

- ❑ This design uses two AC/DC converters rated at 25 % of total generator power with a capacitor between them to control the *WECS*
- ❑ The wound rotor induction generator configuration is also known as a doubly fed induction generator (*DFIG*)

WECS TYPE C

- ❑ The term “doubly” comes from the fact that the rotor winding is not short-circuited – as in the classical “singly-fed” induction machine – but a voltage is induced from the rotor – side converter
- ❑ Depending on the operating scheme, they can keep a constant value of reactive power or keep the terminal voltage constant
- ❑ The *WECS type C* is the most widespread of all wind turbines on the market

WECS TYPE D

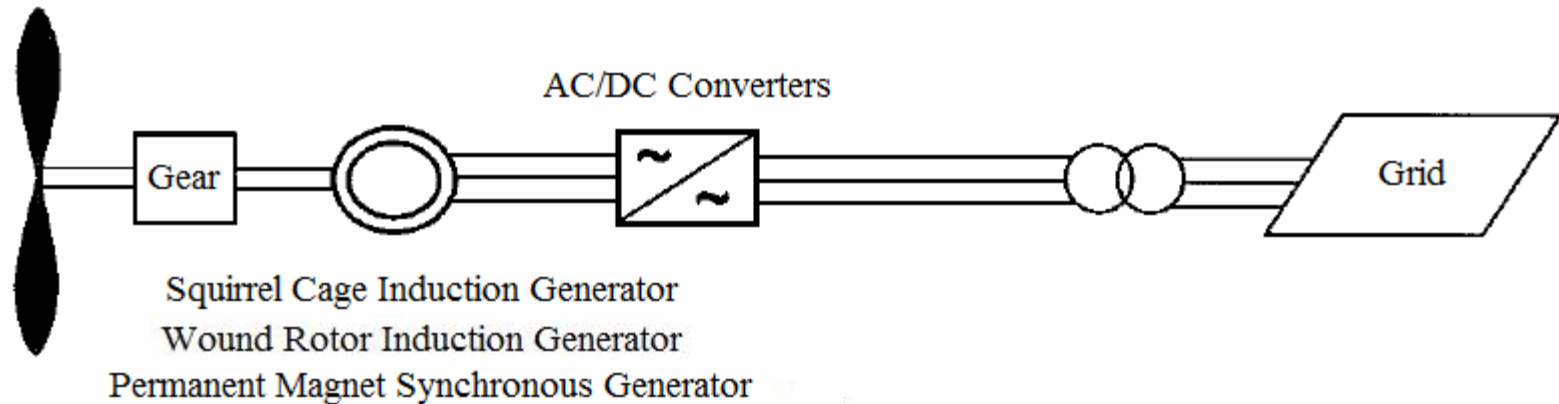

□ The *type D* design uses a full-scale frequency converter with different types of generators

□ The most common implementation is the

permanent magnet synchronous generator (*PMSG*)

WECS TYPE D

- ❑ This design allows full control over active and reactive power production and has a high wind energy extraction value
- ❑ Full power control improves power and frequency stability in the grid and reduces the short circuit power
- ❑ Most *type D* designs do not need a gearbox, which is a great advantage

WIND TURBINE CLASSIFICATION

